

Automatic Passenger Counting

IRMA – Infrared Motion Analyzer 5th generation

IRMA MATRIX Door Clear option Mounting and operating instructions

For sensor versions:

- DIST500-F
- DIST500-A

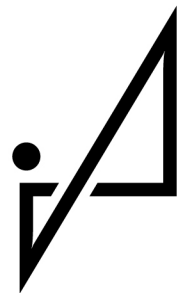

iris INFRARED
INTELLIGENT
SENSORS

Document information

Title of document:	IRMA MATRIX Door Clear option Mounting and operating instructions
File name:	KDBA_IRMA-MATRIX_Door Clear-option_Mounting_and operating_instructions_1.3_en.pdf
Revision:	1.3
Edition (YYYY-MM):	2018-08
Type of document:	Customer documentation
Status:	released

Validity

Sensors covered in this document

Product	Sensor version	Type designation	Description
IRMA MATRIX	DIST500-A	DIST500.7-A07.OC	Surface mount version
IRMA MATRIX	DIST500-F	DIST500.7-F07.OC	Flush mount version

Table of contents

1	General information	4
1.1	Symbols used / Abbreviations.....	4
1.1	What is Door Clear?.....	5
2	Mounting IRMA MATRIX	6
2.1	Placing the IRMA MATRIX sensor	6
2.2	Connection via Ethernet	6
2.3	Connection via CAN direct integration	7
2.4	Connection via gateway IBIS and door control analyzer.....	8
2.5	Connecting the sensor to the PC	9
2.5.1	PC connection via Ethernet.....	10
2.5.2	PC connection via CAN	10
3	Configuring Door Clear	11
3.1	Compatibility	11
3.2	Configuring Door Clear in the DC Configurator	12
3.3	Applying Door Clear in the Config Tool	18
4	How does Door Clear work?	21
4.1	Activating Door Clear.....	21
4.2	Door Clear limitations and conditions of use.....	22
5	Reversing the door status	24
6	Appendix	24











Table of illustrations

Fig. 1:	Monitoring area of the IRMA MATRIX sensor and Door Clear zone	5
Fig. 2:	Signal chain for Door Clear in ETH wiring	7
Fig. 3:	Signal chain for Door Clear with CAN direct integration	7
Fig. 4:	Signal chain for Door Clear in gateway IBIS wiring with door control analyzer	8
Fig. 5:	Pin assignment for Door Clear on the door control analyzer	9
Fig. 6:	Ethernet connection via ETH switch and via the RJ45 connector on the PC	10
Fig. 7:	Enter IP address	10
Fig. 8:	CAN connection via the USB-CAN converter	11
Fig. 9:	First start-up of the program with application note	12
Fig. 10:	Change language	12
Fig. 11:	Program restart with application note	13

Fig. 12: Select sensor.....	13
Fig. 13: Confirm sensor selection with OK.....	14
Fig. 14: Left: currently set Door Clear zone.....	14
Fig. 15: View after applying DELETE.....	15
Fig. 16: Door Clear zone	16
Fig. 17: Test run active, the sensor sets the “Door clear” status.....	17
Fig. 18: Test run active, the sensor sets the “Door not clear” status.	17
Fig. 19: Exit Door Clear configurator	18
Fig. 20: “Door Clear” tab in the Config Tool.....	19
Fig. 21: Writing the configuration data into the sensor	20

1 General information

1.1 Symbols used / Abbreviations

	“Please note”		“Worth knowing”
	“Caution - can lead to defects”		“Information”
	“See appendix!”		“See document (on homepage)”
	“Instructions for action”		“Please record”
	“Please consult iris-GmbH!”		“Download”
Marked gray	Instruction manual (operating software)		
	This arrow indicates setting parameters which must be adjusted for each configuration!		
Door Clear configurator	Abbreviation used for “DIST500-Door ClearConfigurator” software		
sCON-S /-F-12	sensor C onnector – S tandard / Flat – M12 connector		
sCON-F-12-PoE	sensor C onnector- F lat- M12 - P ower- o ver- E thernet		
SELECT SENSOR	Function keys in the software		

1.1 What is Door Clear?

The licensed IRMA MATRIX sensor (**release 2**) **Door Clear** feature can, in addition to passenger counting, detect the presence of persons and objects in the function area. The sensor uses a status message to indicate whether the door can close without obstruction. For this purpose, a 3-dimensional monitoring zone is defined within the sensor's field of view. The intersection of the sensor's field of view and the monitoring zone is called Door Clear zone. If the IRMA MATRIX sensor detects objects or persons in the Door Clear zone, it sets the status "**Door not clear**". Otherwise, it sets the status "**Door clear**".

To check the function area, the "**Door clear**" sensor status can, for example, be queried by the on-board computer at any time.

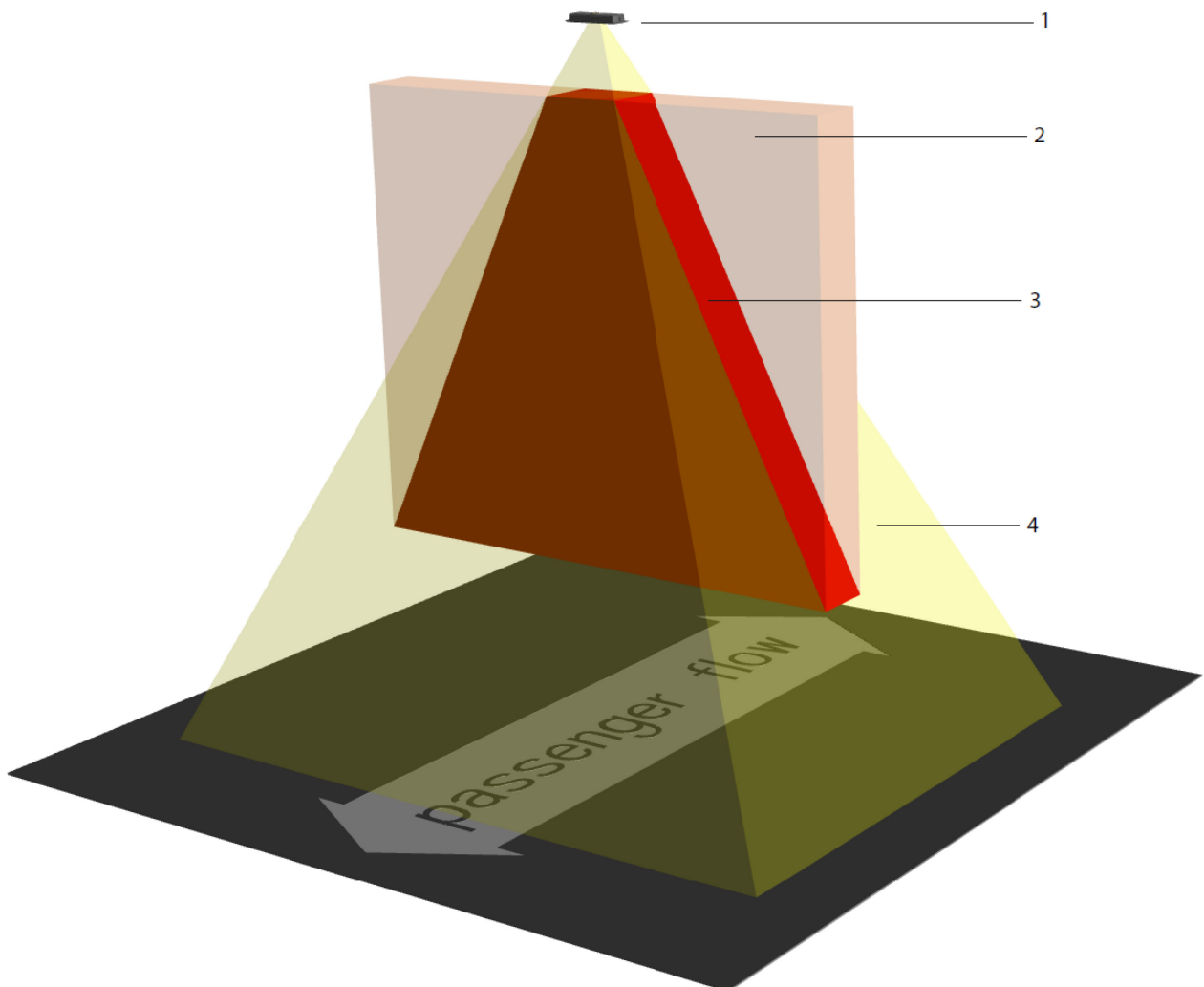



Fig. 1: Monitoring area of the IRMA MATRIX sensor and Door Clear zone

1 IRMA MATRIX sensor (Flush mount version)

2 Configured Door Clear zone

2 Mounting IRMA MATRIX

2.1 Placing the IRMA MATRIX sensor

 In addition to the installation instructions for CAN and Ethernet wiring, please note the following points when placing the sensor **especially for Door Clear**:

- sensor tilt around the x-axis¹ must not exceed 3°.
- sensor must be between 5 - 20 cm away from the door along the y-axis² and
- should be placed above and in the middle of the function area.

 **Non-observance of these points can lead to malfunction of Door Clear!**

2.2 Connection via Ethernet

For a 2-door bus (middle door: approx. 1.25m x 2.10m) with two IRMA MATRIX sensors, for example, install via Ethernet as follows: follow the instructions in the document

 KDIA_IRMA-MATRIX_R2_Installationsanleitung-ETH_1.5, available at: <https://www.irisgmbh.de/technische-dokumente/irma-matrix/>. Fig. 2 shows the simplified Door Clear signal chain for sensor installation via Ethernet.

¹ x-plane = driving direction, y-plane = entry and exit direction, z-plane = vertical direction (up/down)

² ibid.

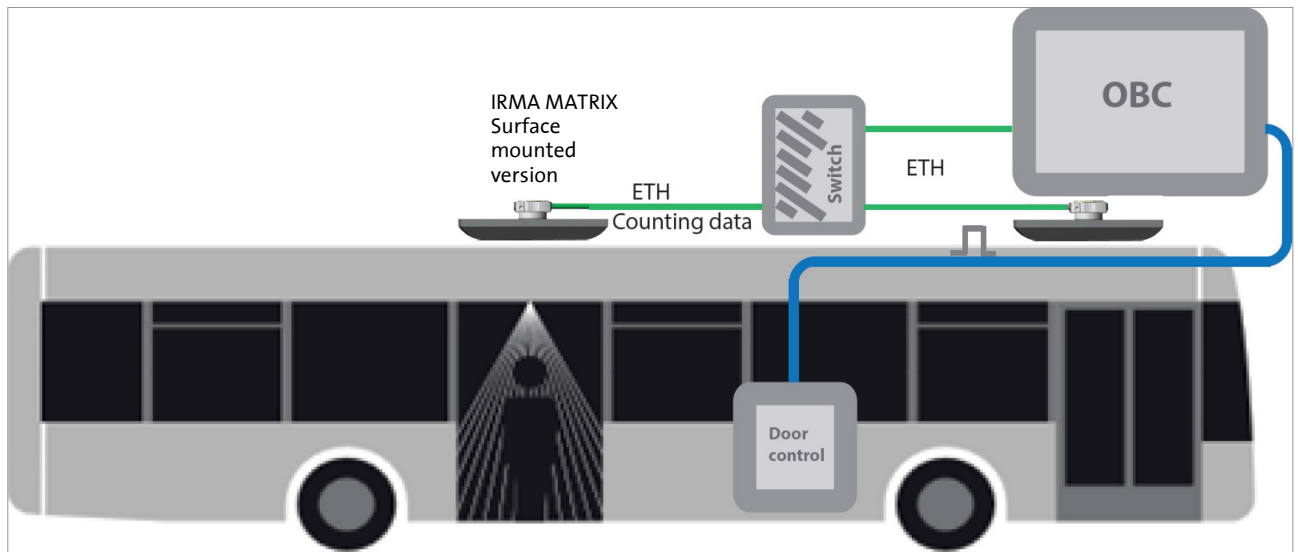

Fig. 2: Signal chain for Door Clear in ETH wiring

2.3 Connection via CAN direct integration

For a 2-door bus (middle door: approx. 1.25m x 2.10m) with two IRMA MATRIX sensors, for example, perform the installation via CAN direct integration as follows:
follow the instructions in the document



KDIA_IRMA-MATRIX_R2_Installationsanleitung-CAN_1.5, available at <https://www.irisgmbh.de/technische-dokumente/irma-matrix/>. Fig. 3 shows the simplified Door Clear signal chain for sensor installation via CAN direct integration.

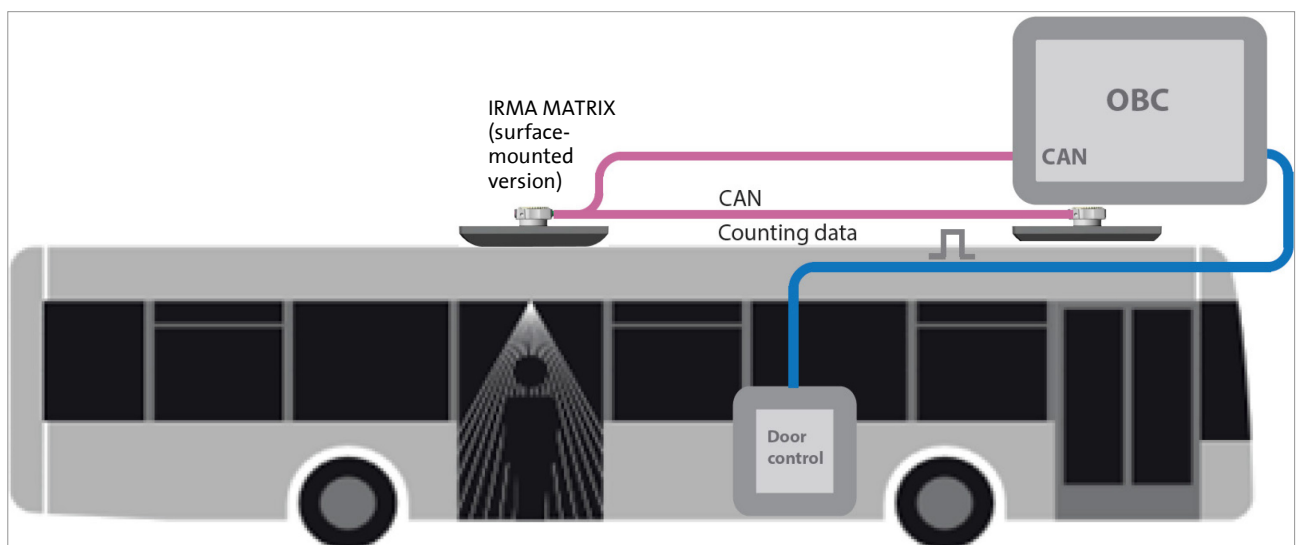

Fig. 3: Signal chain for Door Clear with CAN direct integration

2.4 Connection via gateway IBIS and door control analyzer

For a 2-door bus (middle door: approx. 1.25m x 2.10m) with two IRMA MATRIX sensors, for example, mount via gateway IBIS as follows:

follow the instructions in the document



KDIA_IRMA-MATRIX_R2_Installationsanleitung-CAN_1.5, available at

<https://www.irisgmbh.de/technische-dokumente/irma-matrix/>. Fig. 4 shows the simplified Door Clear signal chain for sensor installation via CAN.

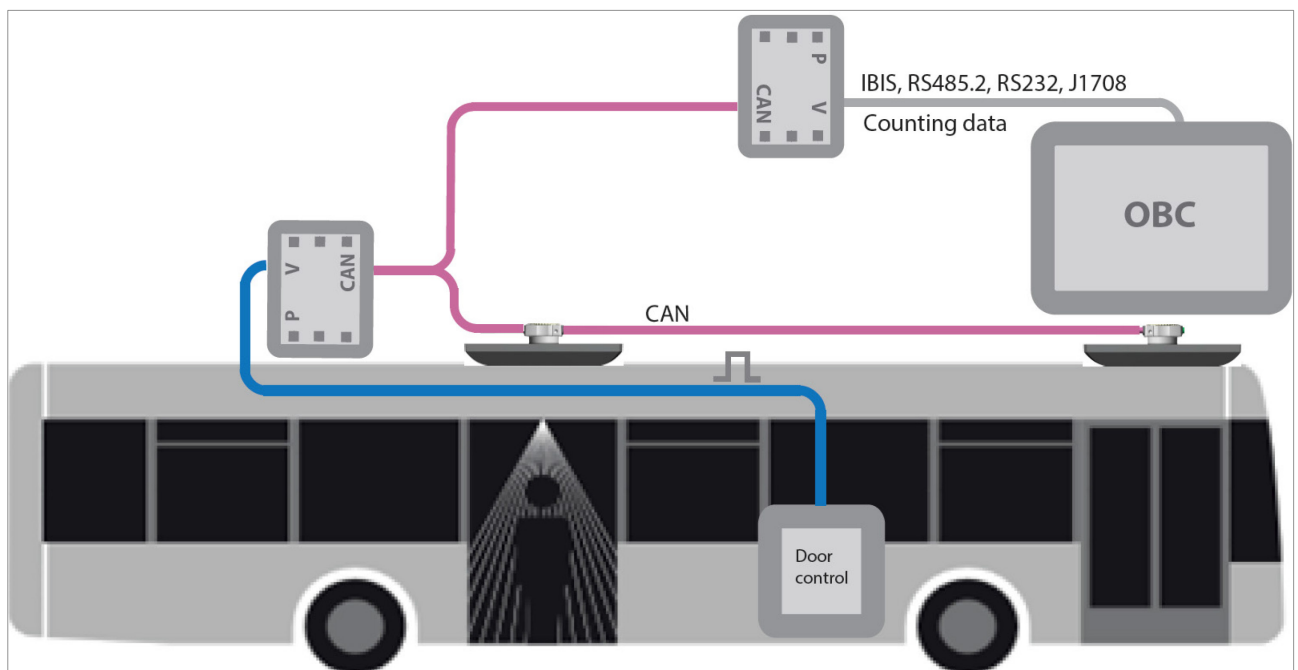

Fig. 4: Signal chain for Door Clear in gateway IBIS wiring with door control analyzer



Note Tab. 1 for the pin assignment of the door control analyzer.

Tab. 1: Pin assignment for door control analyzer

Switch outputs

3	SWa	Out	'a' contact	Door Clear door 1	electrically isolated, suitable for DC and AC, only for protective extra-low
4	SWb	Out	'b' contact		
5	SWa	Out	'a' contact	Door Clear door 2	
6	SWb	Out	'b' contact		
7	SWa	Out	'a' contact	Door Clear door 3	

8	SWb	Out	'b' contact		voltages.
9	SWa	Out	'a' contact	Door Clear door 4	
10	SWb	Out	'b' contact		

 Note Fig. 5 for the “V” outputs of the door control analyzer:

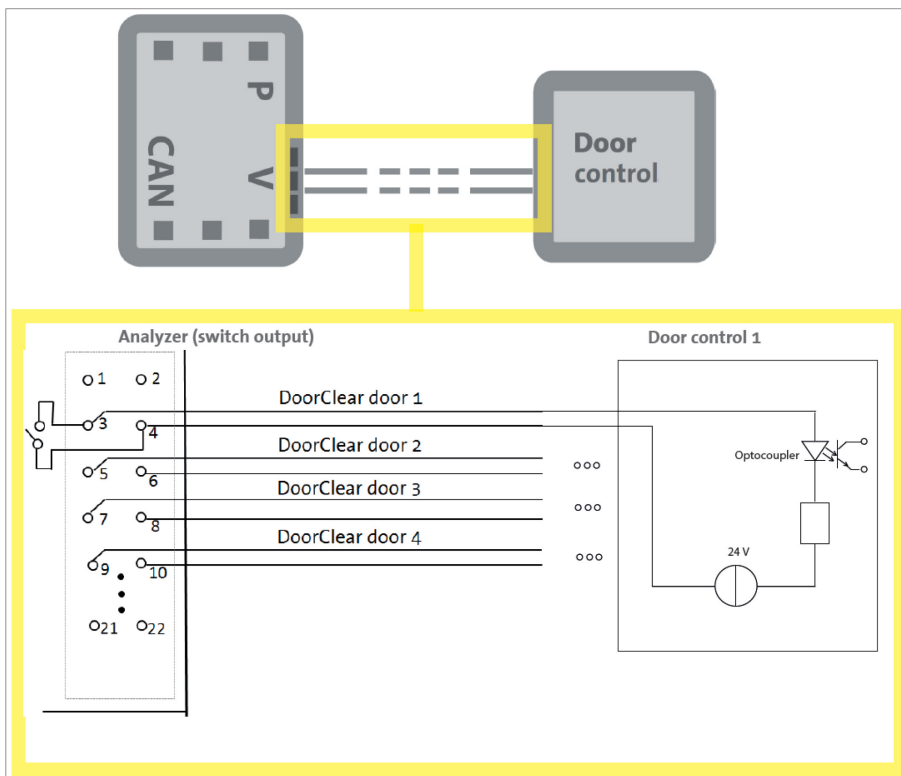

Fig. 5: Pin assignment for Door Clear on the door control analyzer

2.5 Connecting the sensor to the PC

To configure the sensor and Door Clear, you need a laptop with Windows XP, Vista, 7 or 8. The service laptop is connected either via Ethernet or CAN.

2.5.1 PC connection via Ethernet



Connect the sensor to the **RJ45** connector of the PC using the appropriate adapter cable. To do this, the sensor Ethernet interface must be connected to the PC via an ETH switch and a KQ-M12CAT5-RJ45-01-2m (xm) adapter cable. The sensor is supplied with operating voltage via a power supply unit, for example.

Fig. 6: Ethernet connection via ETH switch and via the RJ45 connector on the PC

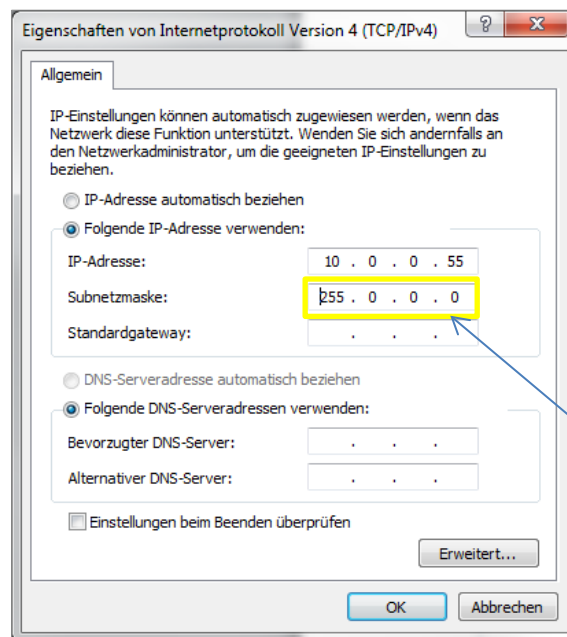

Customizing the network adapter for Ethernet

On your PC, adjust the network adapter under "Control panel" > "Network and Sharing Center" > "Change adapter options" > "LAN connection" > "Properties" > "IP version*".

For the IP address used, enter in "Subnet mask": **255.0.0.0**

Fig. 7: Enter IP address

2.5.2 PC connection via CAN

The PC connection via CAN only affects the sections 2.3 and 2.4 for the signal chains via CAN direct integration and gateway IBIS.

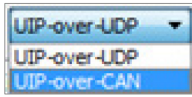

Using a **CAN USB converter** (accessory from *softing*), connect the sensor via to a USB connector on the PC. The sensor must be connected to the CAN-USB converter via a sCON-S-CAN-ETH-23-K2-x-y or sCON-F-12 connector. To connect to the sensor, select the “UIP-over-CAN” driver in the DIST500 Configuration Tool configuration software.

Fig. 8: CAN connection via the USB-CAN converter

3 Configuring Door Clear

If purchased as a licensed feature, Door Clear is an IRMA MATRIX feature in the sensor firmware. You can configure Door Clear in two ways:

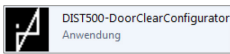

1. In the **DIST500 Door Clear configurator**³, activate the Door Clear feature and configure the Door Clear zone via the graphical user interface. The configuration data is written to the sensor.

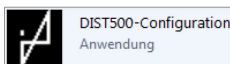

2. In the **DIST500 Configuration Tool**⁴, you can numerically configure the Door Clear zone and generate a configuration report for all parameters⁵.

3.1 Compatibility



Please note that new firmware parameters for the IRMA MATRIX sensor were introduced after DC Configurator version **2.0.0.11** (03/2016). This enables the following compatibilities:

sensor firmware versions from version **2.1.270.4622** work with the DC configurator version **2.0.0.11** (and newer) and with the config tool version **3.9.1.180** (and newer).

³ Hereinafter referred to as “DC configurator”

⁴ Hereinafter referred to as “Config Tool”

⁵ Numerical processing in the Config Tool is only possible if Door Clear has been activated in the DC Configurator beforehand.

3.2 Configuring Door Clear in the DC Configurator

Clicking on  **DIST500-DoorClearConfigurator** starts the DIST500-Door ClearConfigurator.exe program.

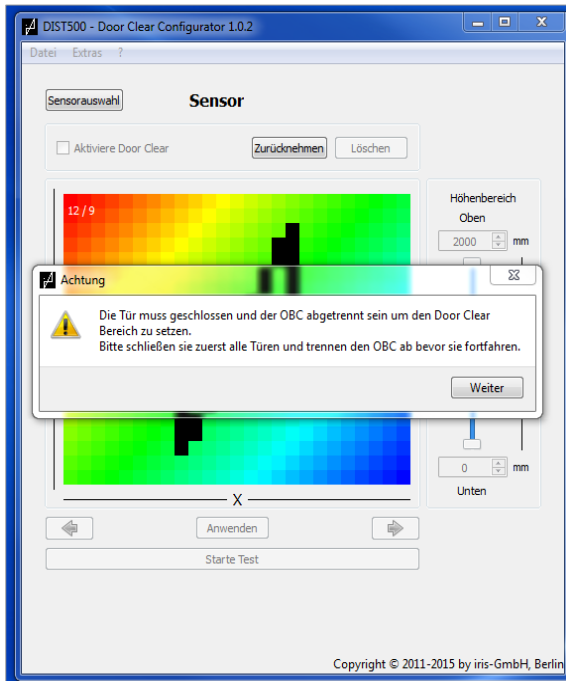

Program start-up

After opening the Door Clear configurator, please note the instructions which appear in the main window:

“The door must be closed and the OBC disconnected to define the Door Clear area. Please close all doors and disconnect the OBC before proceeding.”

Then click WEITER (= continue).

Fig. 9: First start-up of the program with application note

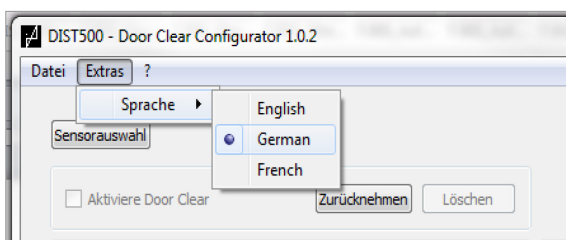

Changing the language setting

If required, click on EXTRAS > SRPACHE (= language) > and choose the desired language.

Fig. 10: Change language

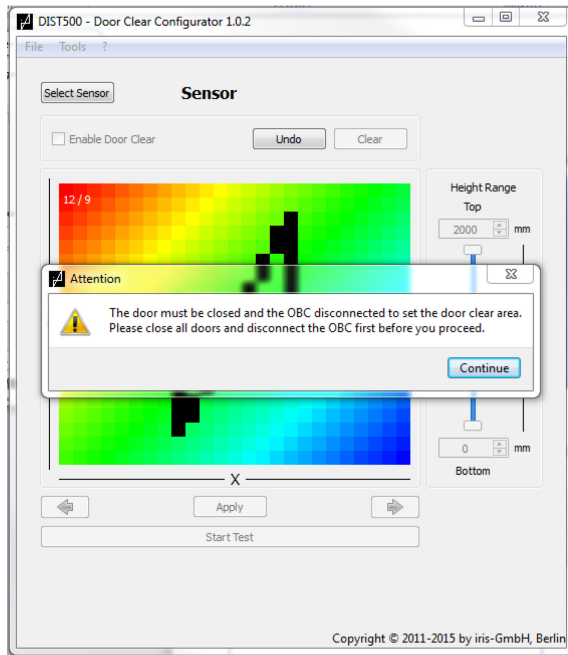

Restarting after changing language settings

Restart Door Clear-Configurator in accordance with the instructions.

Fig. 11: Program restart with application note

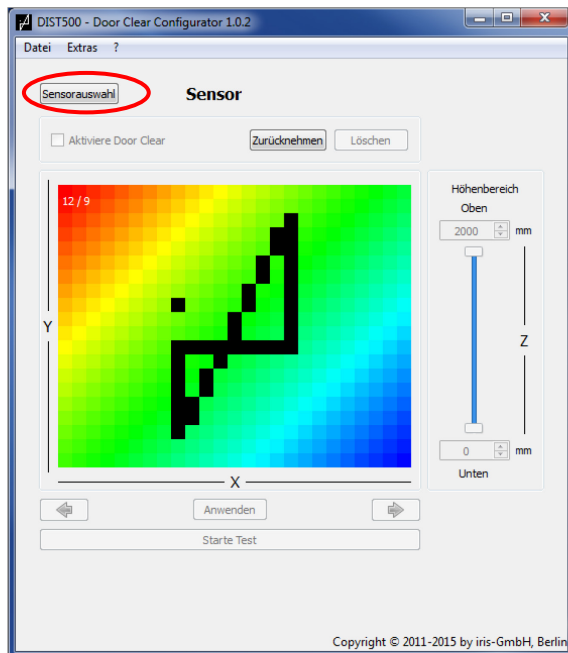

Select sensor

Select the corresponding sensor via click on SENSORAUSWAHL (= sensor selection).

Fig. 12: Select sensor

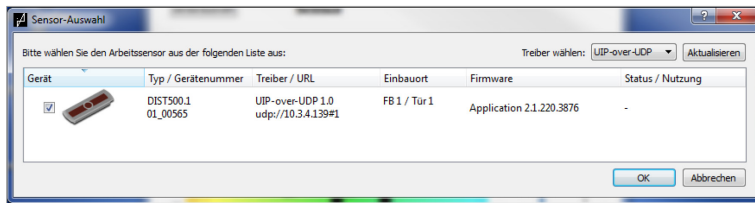

Confirm sensor selection
Select the corresponding sensor and click OK.

Fig. 13: Confirm sensor selection with OK

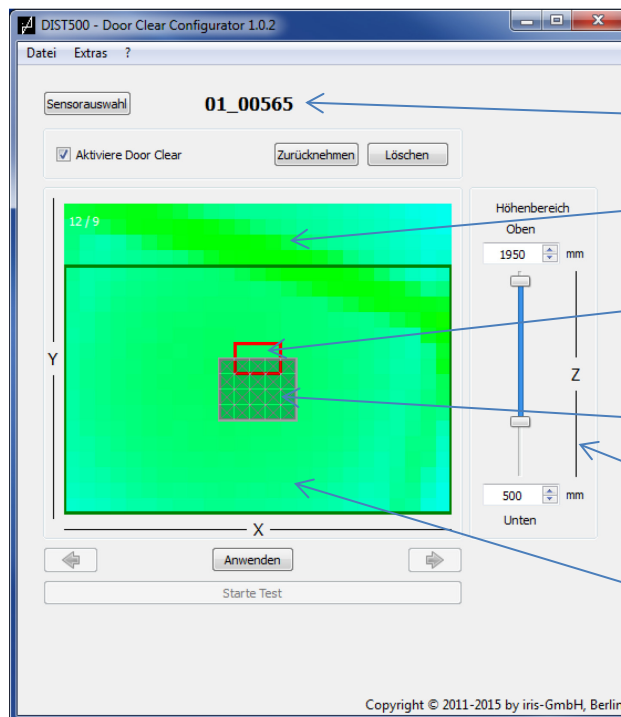

Setting the Door Clear Zone

- ← Sensor device number
- ← Exterior (outside the vehicle)
- ← Optical axis (see p. 22) of the sensor (must be in the configured Door Clear zone)
- ← Door Clear zone in the x-plane and y-plane (must contain the optical axis)
- ← z-plane for determining the height of the Door Clear zone
- ← Interior (inside the vehicle)

Fig. 14: Left: currently set Door Clear zone

AKTIVIERE DOOR CLEAR (= enable Door Clear) activates or deactivates the Door Clear function.



Drawing or amending the Door Clear zone in the x-plane and y-plane

You can enlarge the zone with a mouse click or, after using LÖSCHEN (= delete), pixel it again. The Door Clear zone should be at least 2 x 6 px in size.



Important: The optical axis of the sensor (Fig. 1) must be **within** the configured Door Clear zone! It is **not** possible to place the optical axis outside the Door Clear zone in the DC configurator.

Using LÖSCHEN (= delete), you can delete the defined Door Clear zone to be able to redefine it with the mouse.



Configuring the Door Clear zone in the vertical (z-plane)

In the “Height range”, you can adjust the height of the Door Clear zone using the controller on the z-plane, e.g. to ignore disturbing door functional elements in the upper or lower range.

Using ZURÜCKNEHMEN (= reset), you reset the changed settings to the last saved state.



Press ANWENDEN (= apply) to save the amended settings to the sensor.

Using STARTE TEST (= start test), you start the active sensor function as a test run. In the horizontal (x-y-plane), you can observe the sensor function with the marked Door Clear zone.

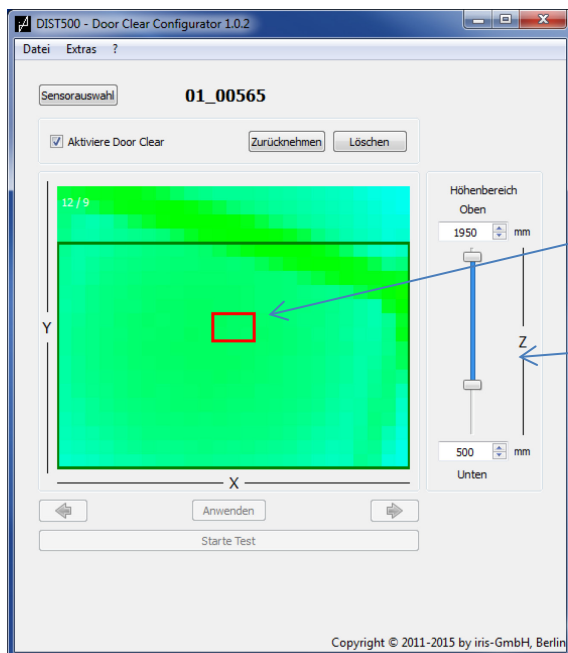

Reset Door Clear after deletion

The optical axis of the sensor is set by default and must always be within the new configuration.

2-fold controller for the height range along the z-plane is still available from the old setting

Fig. 15: View after applying DELETE

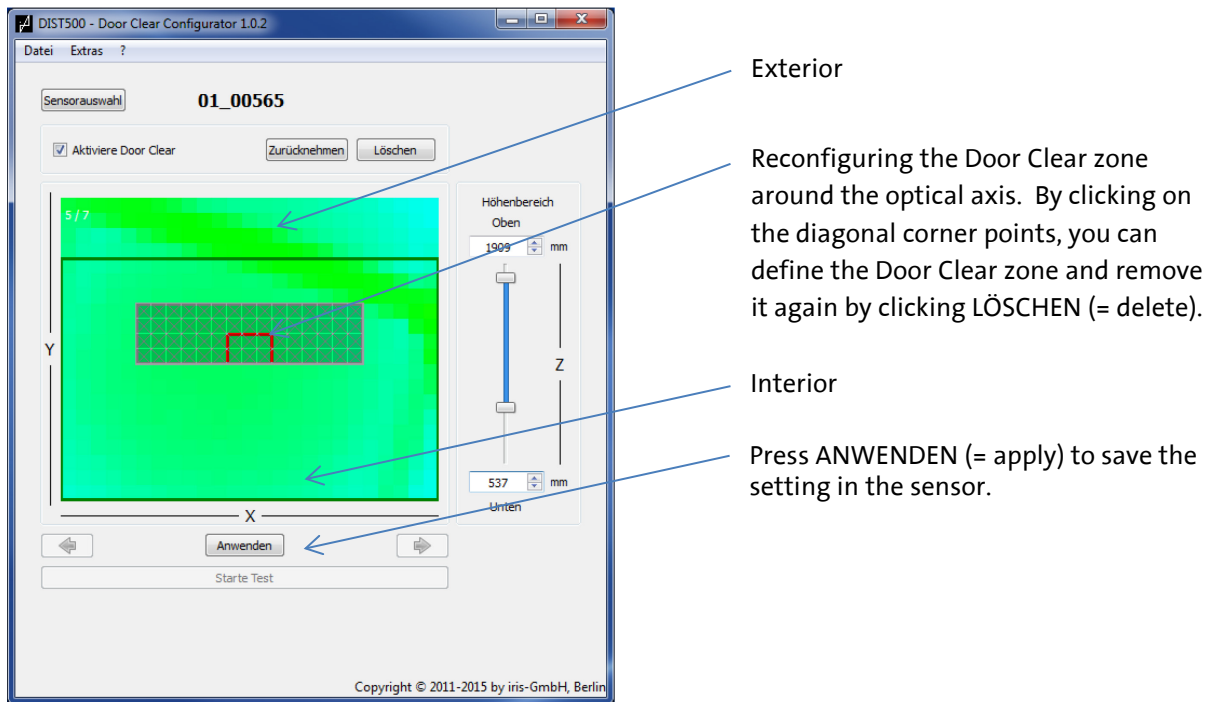
**Fig. 16: Door Clear zone**

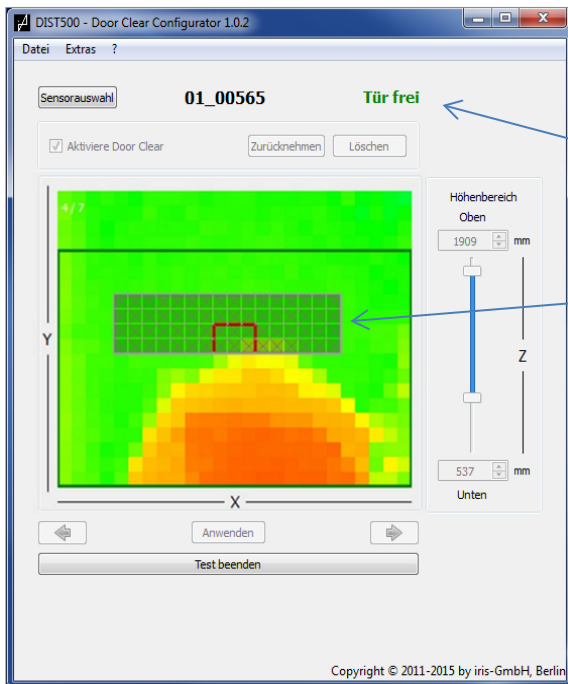
**Start test run**

The Door Clear function is active.
The "Tür frei (= door clear)" sensor status is set.

The Door Clear zone is clear in the
respective x-, y- and z-zones.

Fig. 17: Test run active, the sensor sets the "Door clear" status.

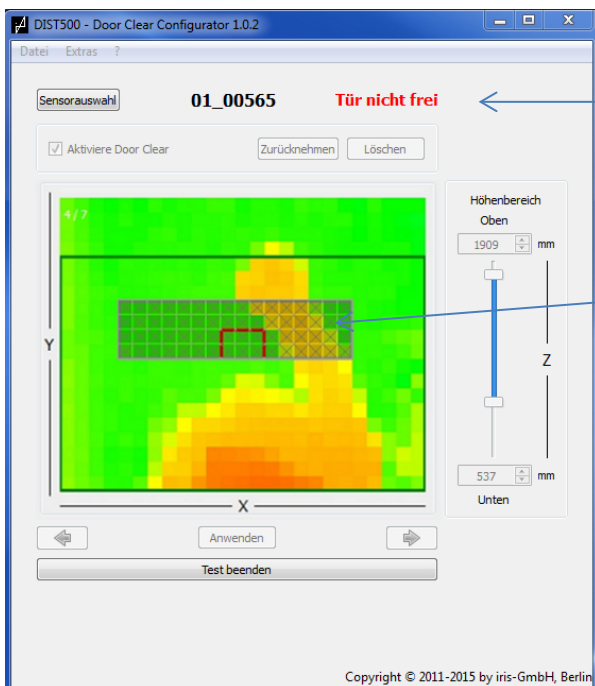

The Door Clear function is active.
The "Tür nicht frei (= door not
clear)" sensor status is set.

There is an arm in the Door Clear zone.

Press TEST BEENDEN (= exit test) to stop
the test.

Fig. 18: Test run active, the sensor sets the "Door not clear" status.

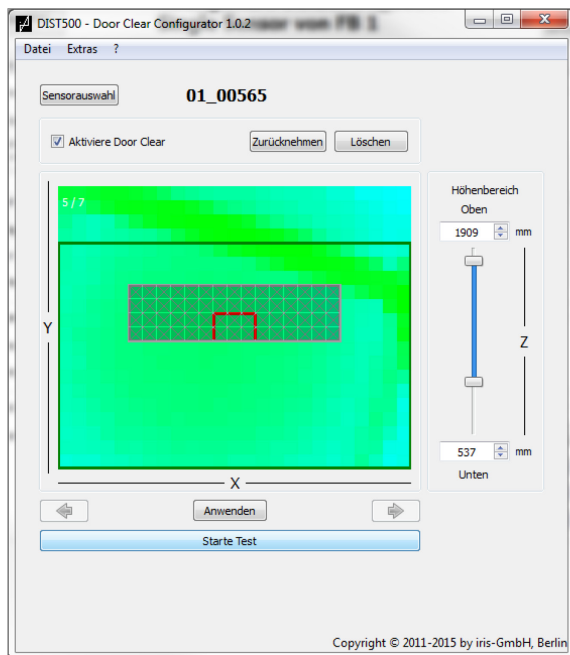

Exit Door Clear configurator

Quit the Door Clear configurator using EXIT.

Fig. 19: Exit Door Clear configurator

3.3 Applying Door Clear in the Config Tool



Close the DC configurator **before** opening the Config Tool. The sensor can only communicate with one tool at a time.

The “Door Clear” tab is only active in the Config Tool if Door Clear was previously retrieved in the DC configurator. In the “Door Clear” tab, you will find the Door Clear zone setting.

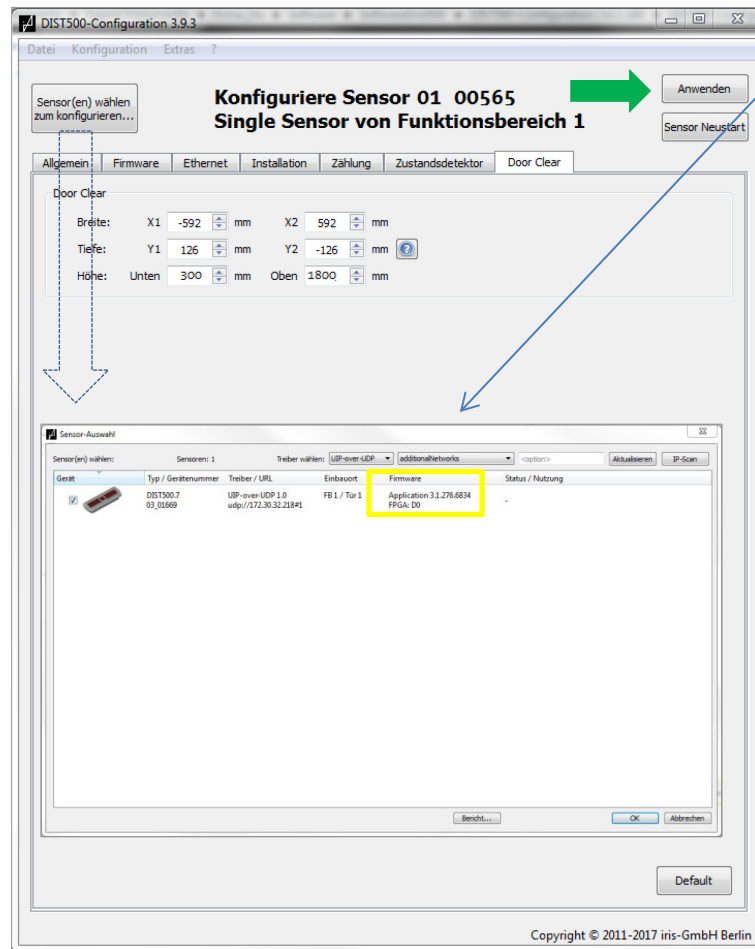

Open the Config Tool. If necessary, check the firmware version to avoid a compatibility issue (see p. 11). In the "Installation" tab, set all parameters according to the installation situation. (For this, see KDIA_IRMA-MATRIX_R2_Installation-manual-CAN (ETH)_1.3, available at <https://www.irisgmbh.de/en/technical-documents/irma-matrix/>) Then check the Door Clear parameters under "Door Clear", amend them if necessary and click ANWENDEN (= apply).

Fig. 20:

"Door Clear" tab in the Config Tool

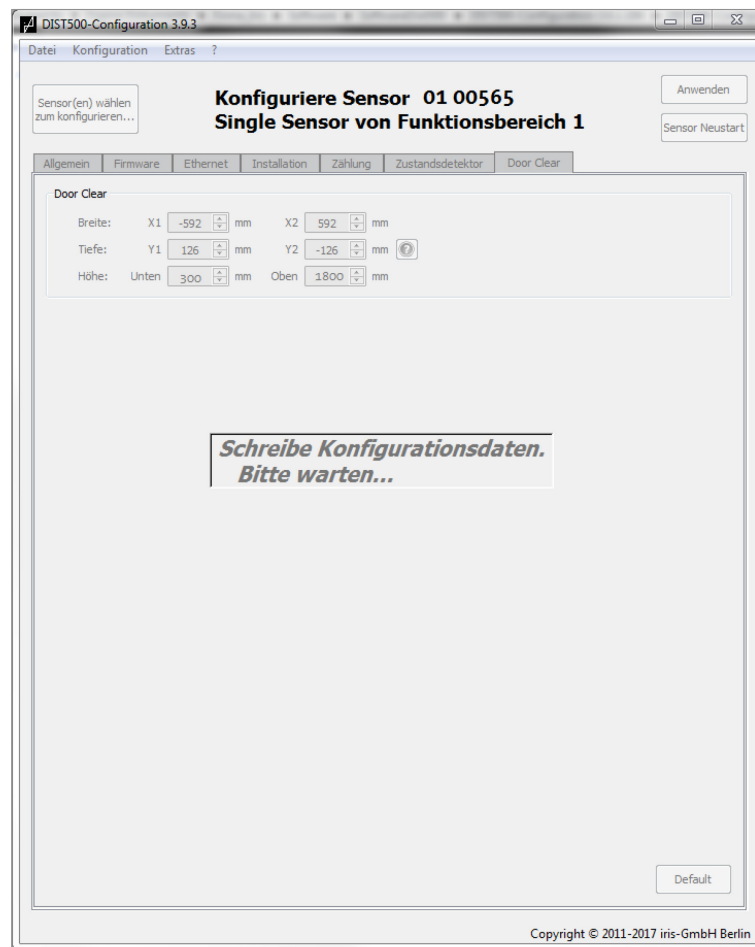

→ All parameters are written into the sensor by the Config Tool.

Fig. 21: Writing the configuration data into the sensor

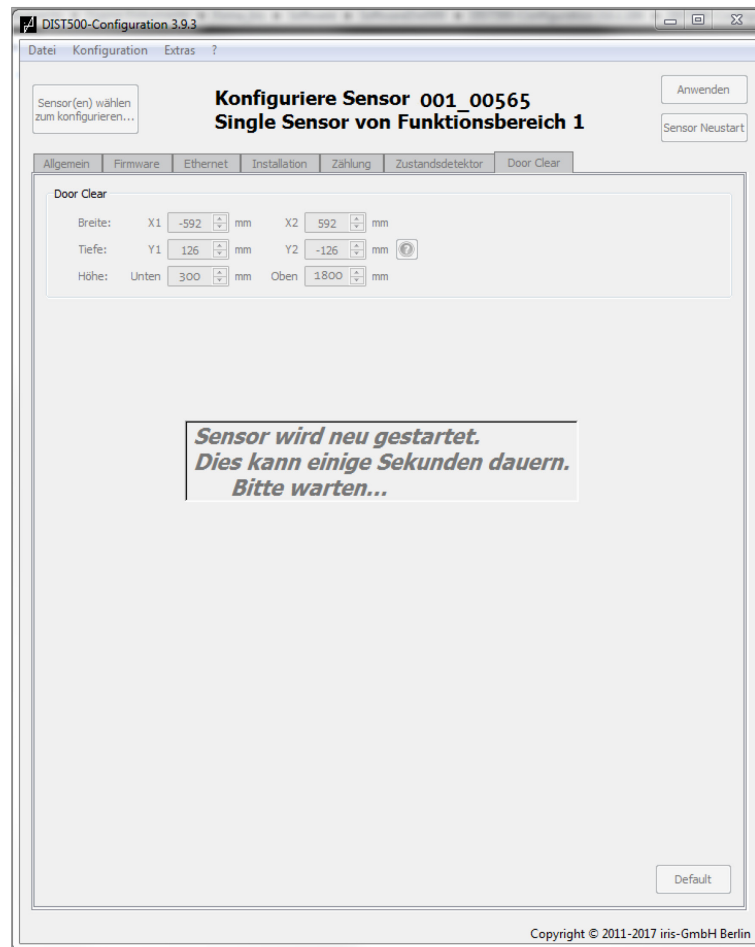

→Then, the sensor is restarted and the Config Tool appears showing the main menu.

4 How does Door Clear work?

4.1 Activating Door Clear

If the Door Clear feature is included in the sensor firmware, the licensed Door Clear feature is automatically activated when commissioning the IRMA MATRIX sensor.



Sensor firmware in which the Door Clear feature is grayed out (as it was not purchased) cannot be configured to activate the Door Clear feature.

4.2 Door Clear limitations and conditions of use



What do I have to consider when installing and commissioning Door Clear?

The following overview describes the characteristics of Door Clear, its application limitations in the function area and which measures you may have to take.

Tbl. 2: Door Clear limitations and conditions of use



Term	Description / Action	Limitation during application
Active Door Clear zone 	<p>The 3-dimensional Door Clear zone, which evaluates the obstacle clearance in the function area, is called the active Door Clear zone in the sensor's field of vision. Due to the pyramid-shaped sensor's field of view, only the shape of a cut-off pyramid is possible for the Door Clear zone. This means that the configured Door Clear volume is cut off by the pyramid-shaped sensor's field of view or defined as a pyramid stump in the field-of-view-pyramid (see Fig. 1).</p>	<ul style="list-style-type: none"> • No evaluation with regard to the Door Clear status of the subareas of the configured Door Clear zone invisible to the sensor • No monitoring of the very close left and right sensor areas
Optical axis 	<p>The optical axis of the sensor is the center of the field-of-view-pyramid and is 90° to the sensor. The optical axis is visible as a red-framed rectangle in the DC configurator. The active and configured Door Clear zone must contain the sensor's optical axis:</p>	<ul style="list-style-type: none"> • A Door Clear configuration outside the optical axis would lead to malfunction, as the sensor firmware always automatically configures the pixelated Door Clear zone around the optical axis, and is not possible!
Shading effect 	<p>If a person/object outside the Door Clear zone interferes with the sensor's view of the active Door Clear zone, independent of obstacles in the active Door Clear zone the sensor always reports a "Clear" status due to the "shading effect". It is therefore important to avoid any shading effect by keeping the distance between the sensor and the DC zone as small as possible (configuration via z-plane, see</p>	<ul style="list-style-type: none"> • Persons / objects located closely under the sensor trigger a shading effect

Fig. 14)

Mounting height

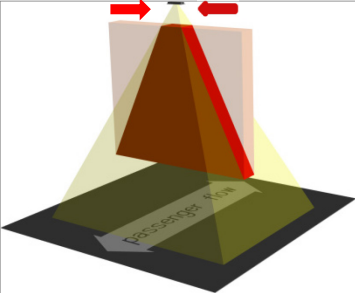
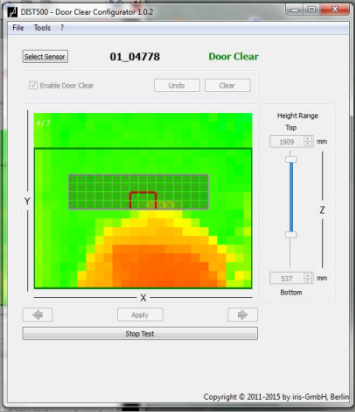

There is a rule of thumb: place the sensor at least as high above the monitored Door Clear zone as the intended width / depth of the active Door Clear zone. Example: The active Door Clear zone should top the optical axis by **50 mm** to the left and to the right. To cover the entire zone width (up to 100 mm), the sensor must be placed **100 mm** above the upper edge of the active Door Clear zone. In the DC configurator, configure the corresponding distance on the z-plane (e.g. 500 - 1800 mm), see Fig. 14.

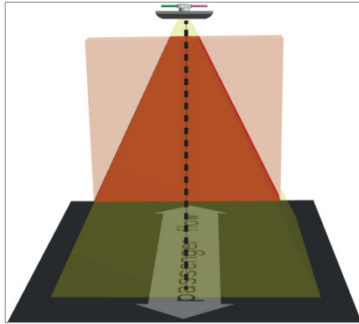
The opening angle of the sensor's field of view α is approx.:

- 40° in entry and exit direction and
- 50° parallel to the direction of travel.

Sensor to door, walls and floor distance

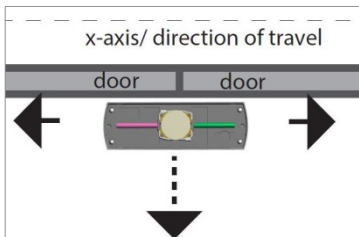
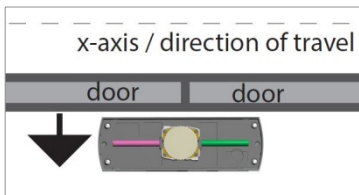

Place the sensor at a distance of **5 to max. 20 cm** from the door to avoid false status messages due to reflections from the glass and a DC zone that extends too far into the room. Strong reflections from walls or floors can cause the sensor to detect interfering objects within the configured Door Clear zone. Leave a distance of at least 200 mm between the configured Door Clear zone and the floor or the reflecting walls. → Avoidance of false, "not clear" door status messages.

- The increased distance between door and sensor reduces malfunctions caused, for example, by glass reflections.
- Occasionally, IRMA MATRIX distance measurements show a fault tolerance, which is caused by different light conditions, specimen and series scattering, aging etc.

Movable door elements

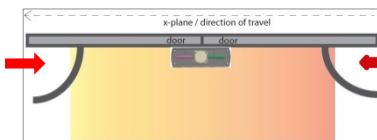

The configured Door Clear zone must not contain any movable door elements. Non-static objects in the surrounding area visible to the sensor are not likely to be regarded as "background". Therefore, measure exactly the space between movable door elements and enter the x and y values in the Config Tool (mm), then click APPLY.

- A door element entering the monitored detection zone triggers a "not clear" status. → Prevents the door from closing

Assessment of the surrounding area with a side effect

An object permanently located in the sensor's field of view in the function area is regarded as part of the surrounding area. The time it takes for an object to fuse with the sensor-internal background

- Luggage located in the active Door Clear zone, which leads, for example, to an "not clear" status



display depends on how long the sensor was previously active and how long the object does not change its shape.

Without having to adjust the settings for Door Clear, this characteristic allows to change the surrounding area of the sensor (handles, trash can, fire extinguisher,...).

disappears within minutes if left untouched. The Door Clear status may switch to "clear" if no other mobile objects are observed within the Door Clear zone.

5 Reversing the door status

For reasons of stability, a change of the Door Clear status must be detected on several consecutive images before the status change is communicated. If the sensor communication is implemented via Ethernet, the so-called **response time**, for example, is approx. 100 ms.

As the normal CAN IRMA communication cycle (no request of buffered counting results by the end-of-counting event) takes approx. 150 ms if 4 DIST500 sensors are connected to the gateway, the time delay is considerably higher if the IRMA MATRIX sensor is connected via the CAN BUS.

If the software runtime delay and the duration of the analyzer output pulse of 100 ms are added, the total delay from the actual change in the door status to the start of the door inversion is in the range of approx. **200 ms** (single door) to approx. **400 ms** (4-door, i.e. 4 DIST500).

6 Appendix

Please see below for the wiring diagrams for the connections via

- **CAN direct integration** (pg. 26),
- **Gateway IBIS switching output** (pg. 27).
- **Ethernet**

- using **sCON-S** (pg. 28),
- using **sCON-F-12** (pg. 29) and
- using **sCON-F-12-PoE** (pg. 30).

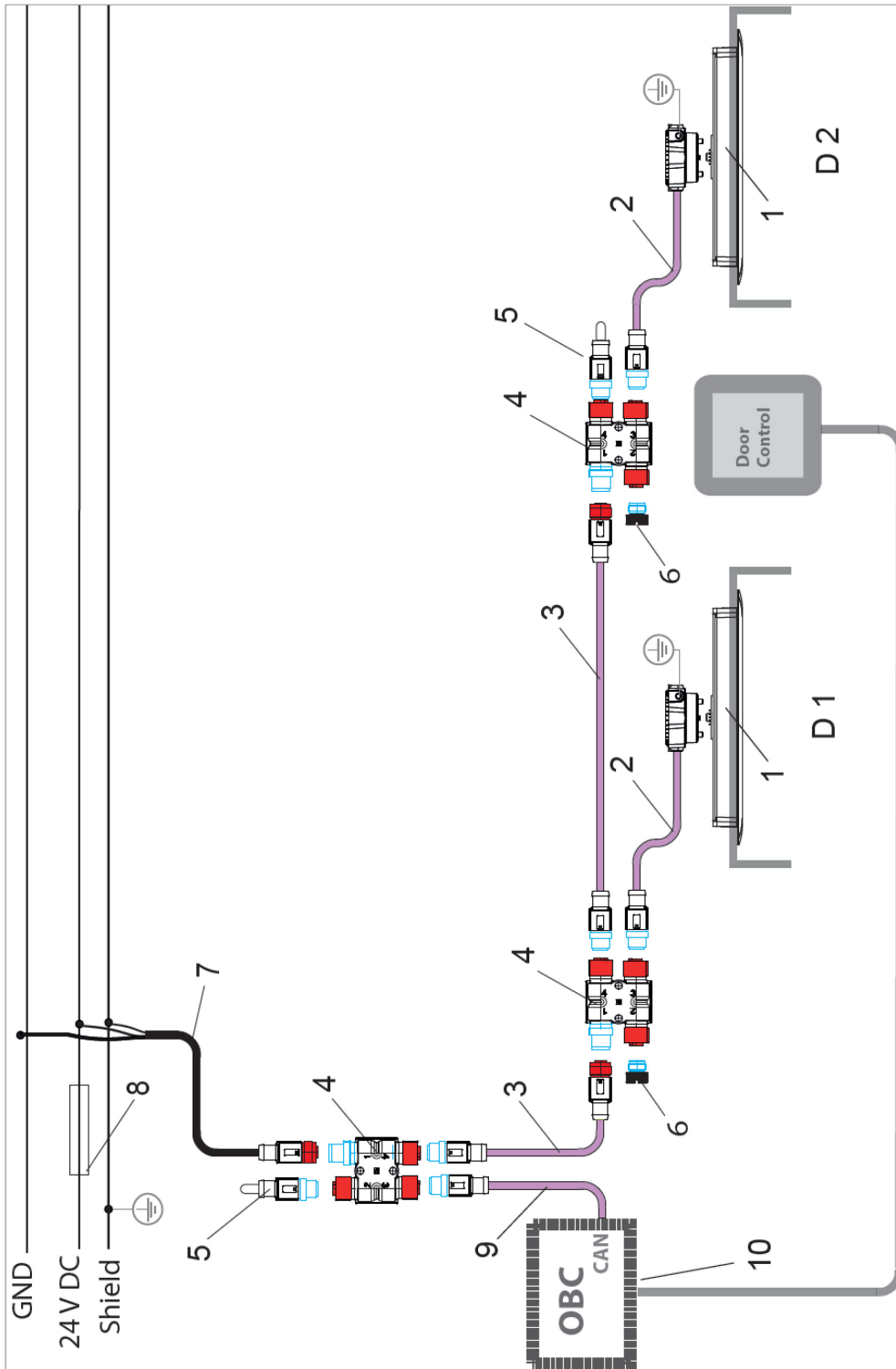

Fig. 1: Wiring diagram for CAN direct integration

- | | |
|---|--|
| <p>1 IRMA MATRIX sensor (built-in version)</p> <p>2 sCON connector for sCON-S-CAN-22-Kn-1-2m CAN connection</p> <p>3 M12 extension cable, CAN type, K-M12CAN-XX-x</p> <p>4 M12-CAN-H distributor with cap, M12CAN-CON-03</p> <p>5 M12 male terminator, M12CAN-TR-02</p> | <p>6 Sealing cap</p> <p>7 M12 voltage supply cable</p> <p>8 Fuse</p> <p>9 Adapter cable M12 to SubD9 K-A21-M12CAN-0x-32cm</p> <p>10 Still to be defined</p> <p>D 1 D2 Function area 1 and 2</p> |
|---|--|

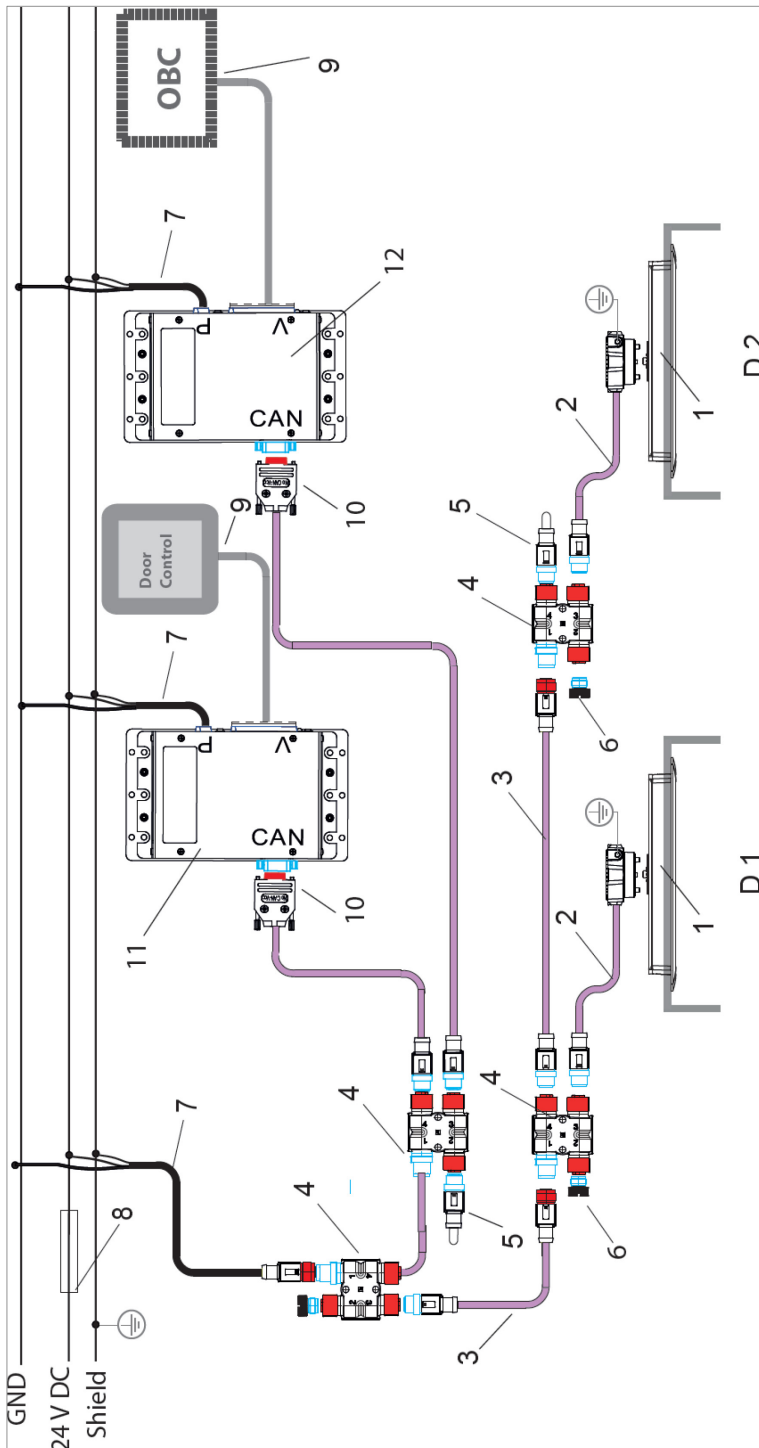

Fig. 2: Wiring diagram for gateway IBIS and switching output

- | | |
|--|--|
| <ul style="list-style-type: none"> 1 IRMA MATRIX sensor (built-in version) 2 sCON connector for sCON-5-CAN-22-Kn-1-2m CAN connection 3 M12 extension cables, CAN type, K-M12CAN-XX-x 4 M12-CAN-H distributor (opt. with cap) M12CAN-CON-03 5 M12 male terminator, M12CAN-TR-02 6 Sealing cap D1, D2 Function areas 1 and 2 | <ul style="list-style-type: none"> 7 M12 voltage supply cable 8 Fuse 9 Still to be defined 10 Sub-D9 male connector for CAN connection 11 Analyzer with switching output to the door control unit using K-A21-M12CAN-01-32cm, 12: Gateway IBIS to OBC using K-A21-V-IBIS-07-15-15-15-15-15-15m |
|--|--|

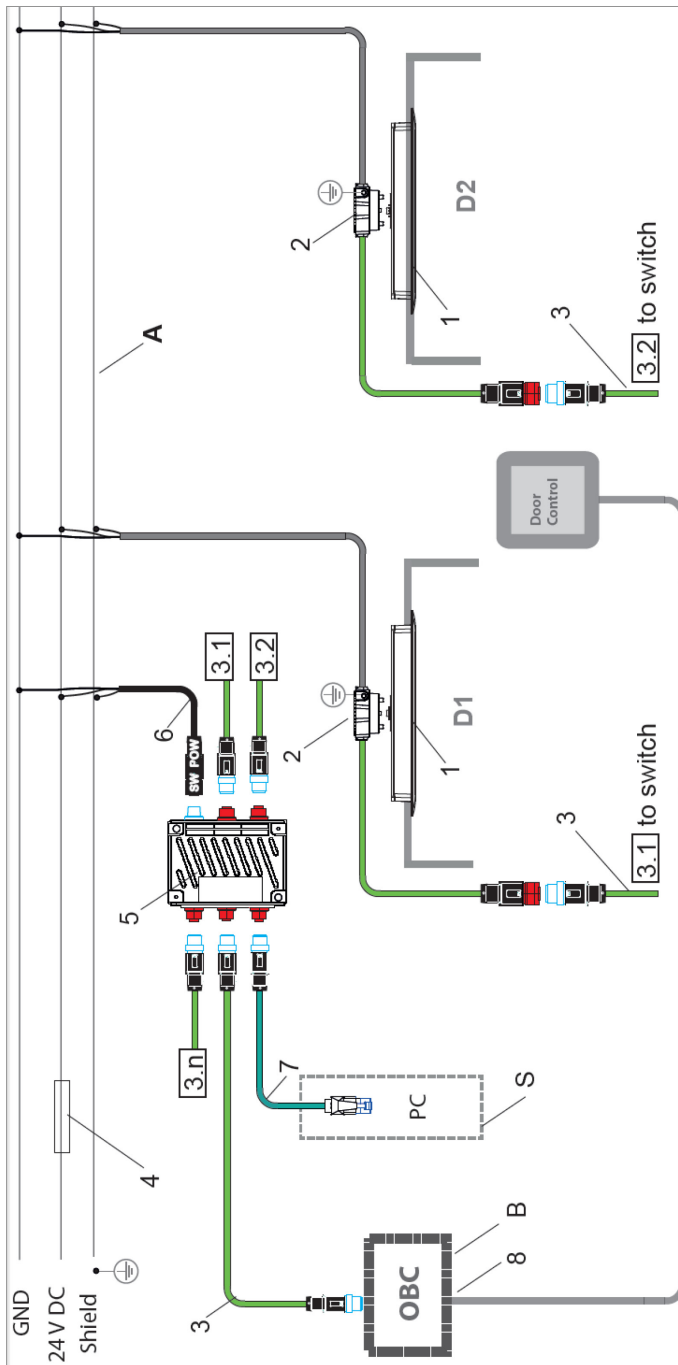





Fig. 3: Wiring diagram for Ethernet using sCON-S

<p>1 IRMA MATRIX sensor (built-in version) 2 sCON-S-Connector for sCON-S-ETH-22-Kn-1-2m Ethernet connection 3 M12 system Ethernet cable K-M12CAT5-XX-xm 4 Fuse 10A, fast 5 M12 switch: Switch-M12-5Port-eCon Power (=K2); or SAC-4P-5,0-28R/FS SCO RAIL (=K3) 6 Power cables for switch; K-Switch-Power (=K2); or SAC-4P-5,0-28R/FS SCO RAIL (=K3)</p>	<p>7 KQ-M12CAT5-RJ45-01-xm adapter cable for PC connection for support services 8 Still to be defined A Distribution of the on-board power supply to each door for connecting sensors and switches. The distribution of the on-board power supply to each door is not part of the standard scope of supply of iris-GmbH! B Connection to On-Board Computer/Unit PC connection for support services</p>	<p>D1, D2 Function area 1 and 2  M12 female connector, ETH type  M12 male connector, ETH type  SW POW M12 female connector, ETH type, 4-pole, A-coded (K-Switch-Power)</p>
---	---	--

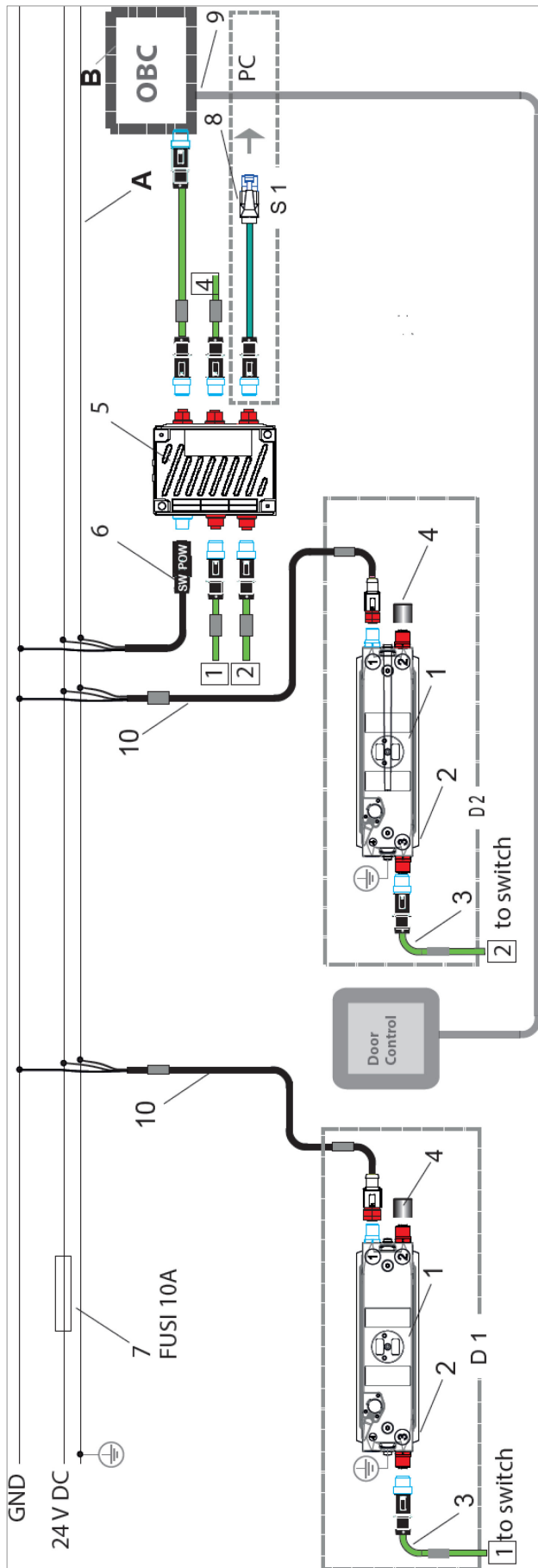

Fig. 4: Wiring diagram for Ethernet using sCON-F-12

<p>1 sCON-F-12 2 IRMA MATRIX sensor (built-in version) 3 M12 system Ethernet cable K-M12CAT5-XX-xm 4 Sealing cap 5 M12 switch: Switch-M12-5Port-eCon 6 Power cables for switch: K-Switch-Power (=K2); or SAC-4P-5.0-28R/FS SCO RAIL (=K3)</p>	<p>7 Fuse 10A, fast 8 KQ-M12CAT5-RJ45-01-xm adapter cable for PC connection for support services 9 Still to be defined 10 M12 power supply cable A Distribution of the vehicle-side power supply to each door for connecting sensors and switches. The distribution of the on-board power supply to each door is not part of the standard scope of supply of iris-GmbH! B On-Board Computer/Unit PC connection for support services</p>	<p>D1, D2 Function area 1 and 2 M12 female connector, ETH type M12 male connector, ETH type SW POW M12 female connector, ETH type, 4-pole, A-coded (K-Switch-Power)</p>
---	--	--

